

GEN. ST.	01	02	03	04	05	06	07	08	0D	50	60	70	80	90																	
INT. ST.	10	11	12	13	14	18	20	31	32	33	34	38	39	40	42	43	44	45	46	48	56	70	72	73	75	76	81	82	83	84	88

REV.	DATE	DESCRIPTION	BY	C'K'D'
A	14-09-01	CONVERSION REVISION 07	KN	
B	23-11-05	105-0251	ALEX B	BKP
07	310501	BEC 9.3525	R.M.	

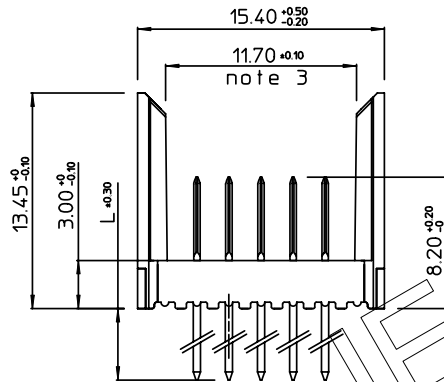
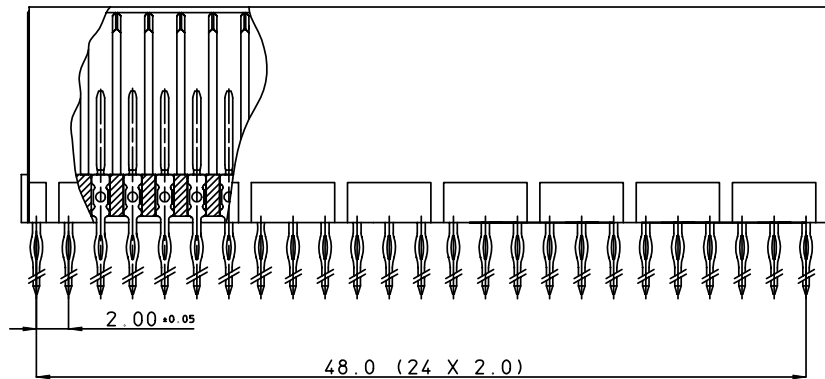

PERFORMANCE CHARACTERISTICS

CURRENT RATING : 1.5 A AT 20°C (FULLY LOADED)
 1 A AT 70°C (FULLY LOADED)
 RATED VOLTAGE : 500 V AC (CONT / CONT)
 OPERATING TEMPERATURE : -55°C TO 125°C
 CONTACT RESISTANCE : 20 mΩ MAX
 INSERTION FORCE : 0.75 N MAX / CONT
 EXTRACTION FORCE : 0.15 N MIN / CONT
 INSULATION RESISTANCE : 10⁴ MΩ MIN

CAT. NR.	L ±0.3	DESCRIPTION
HM2P08PD5110----	3.7	SHORT PRESS-FIT
HM2P08PC5110----	4.5	SHORT PRESS-FIT
HM2P08PK5110----	13	REAR PLUG-UP: LEVEL 1
HM2P08PM5110----	14.5	REAR PLUG-UP: LEVEL 2
HM2P08PN5110----	16	REAR PLUG-UP: LEVEL 3
HM2P08PT5110----	13	WIRE WRAP

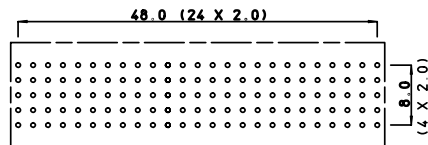
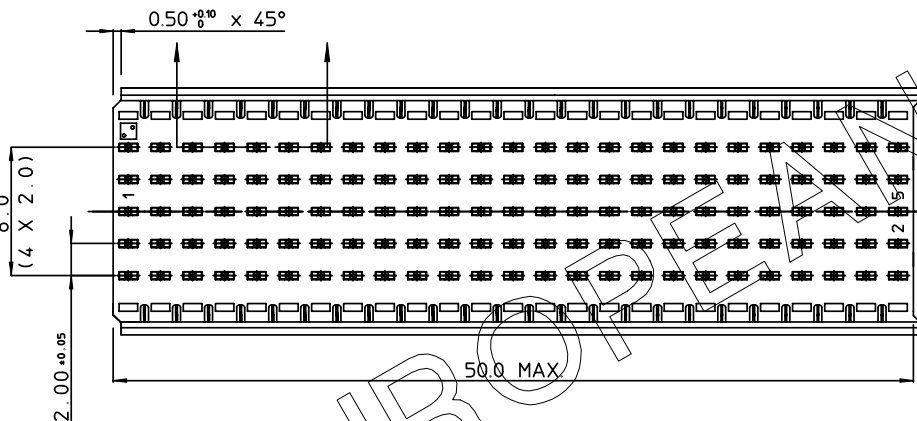

LAY-OUT
P.C.B. - HOLE

NOTES

- *HM2P08P#5110---*
 PERFORMANCE LEVEL INDICATOR (REFER DWG No. BS.C ,201844.003)
 LEAD FREE INDICATOR : LF=LEAD FREE (DIGIT 15&16)
- THIS PRODUCT IS CSA APPROVED.
 THIS PRODUCT IS UL RECOGNIZED.
- MEASURED AT THE BOTTOM.
- FOR RECOMMENDED PTH DIMENSIONS REFER DRAWING : BS.A ,201572.001
- THE PRODUCT (LF) MEETS EUROPEAN UNION DIRECTIVES AND OTHER COUNTRY REGULATIONS AS DESCRIBED IN GS-22-008

MALE SIGNAL STRAIGHT PRESS-FIT-TO-BOARD CONNECTOR
 WITHOUT SERVICECENTER (WIDE BODY)

1DEC ±0.2 1DEC	APPR.	DATE	SIGN.	MILLIPACS 2 / TYPE B / NO SHIELDING
2DEC ±0.1 2DEC	DRAFT	080693	W.Panis	CAT. No. HM2P08P#5110----
ANGLES ±1° HOEKEN	CHECKED			
WE RESERVE THE RIGHT TO CHANGE DIMENSIONS OR REQUIREMENTS WITHOUT PRIOR NOTICE.	PROD. MGR.			FCI MECHELEN N.V. A. SPINOYSTRAT 8, 2800 MECHELEN
	PR. ENG. MGR.			
ALL DIMENSIONS IN MM	PR. MGT. MGR.			3 / 1

	REFERENCES / REFERENTIES	BS,C ,201632,002 B
--	--------------------------	-----------------------

THIS IS OUR EXCLUSIVE PROPERTY. IT IS NOT TO BE COPIED, REPRINTED OR DISCLOSED TO A THIRD PARTY, NOR USED FOR MANUFACTURING WITHOUT OUR WRITTEN CONSENT, AND HAS TO BE RETURNED TO US IN CASE OF NO USAGE

DIT IS ONZE EIGENDOM EN MAG NIET NAGEMAAKT, HERDRUKT, OVERGEMAAKT AAN DERDEN, NOCH VOOR FABRIKATIE GEBRUIKT WORDEN, ZONDER ONZE SCHRIFTELIJKE TOELATING. BIJ NIET GEBRUIK IS TERUGZENDING VERPLICHT.